



Application Note AN014

Designing an EMI Compliant 802.3af PD with the AS1113 and AS1114

Revision 1.2 - November 2017

CONTENTS

Contents	2
General Description	3
Common Mode Noise in Traditional PoE Systems	3
Architecture and DC-DC Converter Topology for low Common-mode noise.....	5
Summary	6
Notes	7
Contact Information	8
Important Notices.....	8
Legal Notice	8
Life and Safety Policy	8

GENERAL DESCRIPTION

The AS1113 and AS1114 are single-chip Powered device (PD) controllers for Power over Ethernet (PoE). Applications include Voice over IP (VoIP) Phones, Wireless LAN Access Point, Security and Web Cameras, Analog Telephone Adapters (ATA) and Point of Sales Terminals.

The AS1113 and AS1114 are intended for 13W applications, per the IEEE 802.3at standard for Type 1 PDs. Both devices can interface directly to the network cable through Ethernet transformers and provides the PD and an integrated DC-DC controller. High integration minimizes the number of components and improves reliability. The AS1113 and AS1114 can be used with standard Ethernet transformer modules to allow the system designer to develop Ethernet networking systems that will meet all relevant EMC standards for EMI emissions, immunity and Surge/ESD protection.

AS1113 and AS1114 have been architected and designed to address many EMI concerns in POE applications. The devices implement many design features that minimizes transmission of system common-mode noise on to the UTP. Any common mode noise that leaks on to the UTP will show up as Conducted or Radiated EMI, depending on the frequency. Controlling the behavior of the DC-DC converter in the AS1113 and AS1114 is critical in the management of electro-magnetic emissions.

COMMON MODE NOISE IN TRADITIONAL POE SYSTEMS

There are various sources of Common-Mode noise in a PoE PD system. On the data transmission side, the Ethernet standard uses differential signaling. However the transmission path of the differential signals are never perfectly matched. This imbalance can be caused by mismatches in the lengths of the transmission lines and mismatches in line capacitance caused by vias or nearby power planes. Other contributors are mismatches in the transmitting output buffers, mismatches in the receiving input buffers, and finally mismatches in the transformer windings. These imbalances cause differential to common mode signal conversion. Any common mode signal that passes onto the twisted pair cable will contribute to radiated emissions.

PoE can be particularly challenging since any noise from PoE DC-DC switcher and other downstream switched can be coupled onto the data channel through the center tap of the Ethernet transformer. A secondary auto-former is often used in conjunction with the Ethernet transformer to provide a direct low impedance common mode path from the data lines to the chassis ground. The center-tap connections are useful in matching the common mode impedance of the cable and reducing common mode noise coming into the receivers. However, PoE applies power to the center taps of the transformers and auto-transformers, which provides a conduit for launching noise onto the cable. Excessive noise from the switching DC-DC converters can have a low impedance path onto the UTP cable, creating a significant EMI issue. The best way to prevent this noise from getting on the Ethernet cable is to add common-mode chokes in that path. Switchers typically operate in 100-500KHz freq range, and tend to have dV/dt based noise transients in 10-50 MHz range. Typical magnetic chokes are not very effective in low frequency ranges and that necessitates use of multiple or larger chokes to meet the emission requirements.

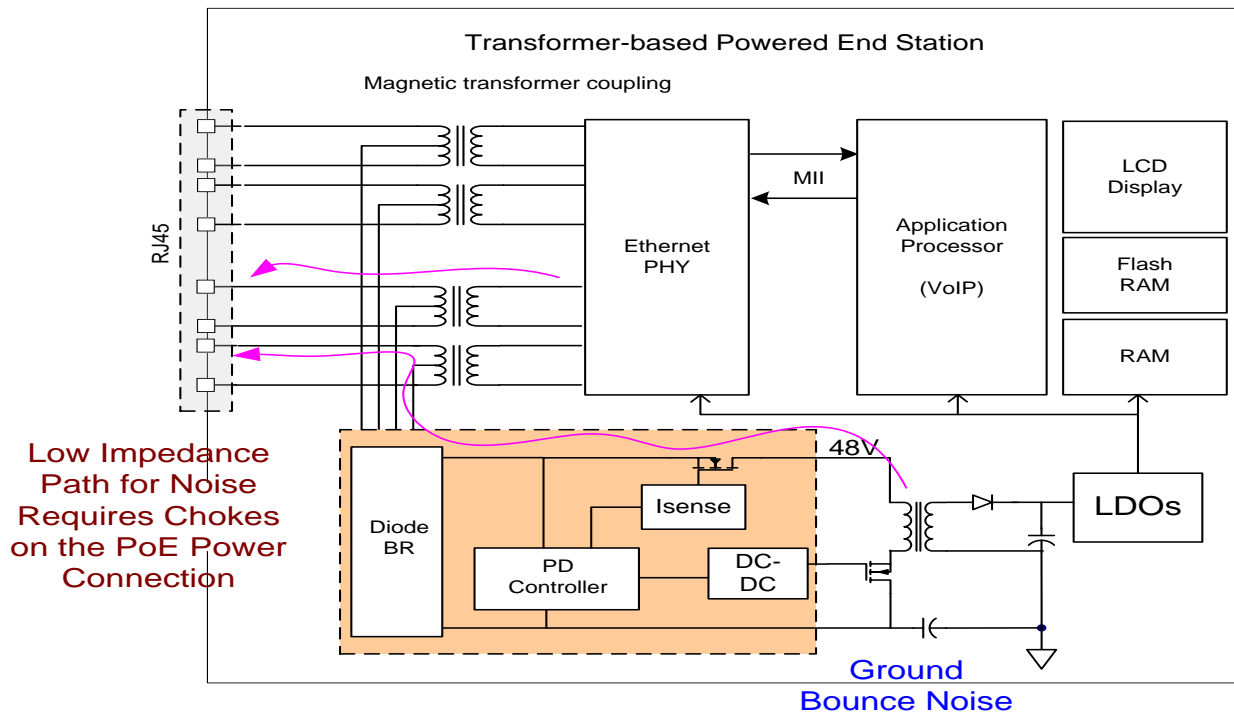

Figure1: Conventional POE System

ARCHITECTURE AND DC-DC CONVERTER TOPOLOGY FOR LOW COMMON-MODE NOISE

AS1113 and AS1114 designs take a system level approach to address the emission issues in PoE PD. The DC-DC switching controller uses a power transformer that is optimized for low switching noise and is optimized to reduce common mode noise between high and low voltage ground planes. As part of full system level solution for EMI, Kinetic has focused significant effort in reducing switching noise in the AS1113 and AS1114 converters, through the following techniques:

- Dual FET topology drives the power transformer differentially, reducing charge injection across C_{int}
- Energy in leakage inductance is recycled locally, reducing primary side noise
- Transformers with low inter-winding capacitance result in lower ground bounce and EMI
- Balanced switching FET drivers to minimize switching noise (dV/dt)

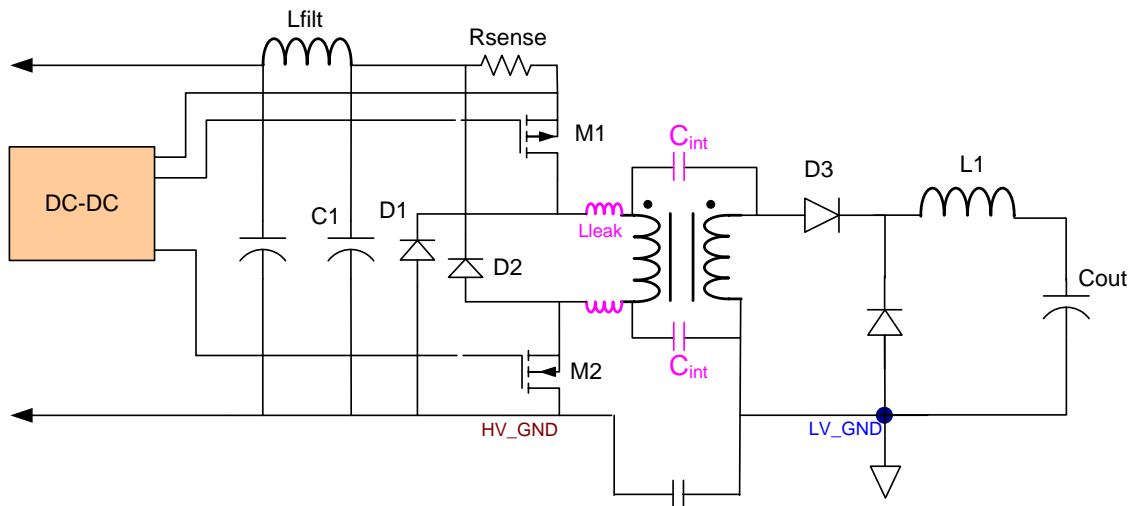

Figure 5: AS1113 and AS1114 Low Noise, Dual FET based Forward DC-DC Converter Topology

The Kinetic PDs implement a dual-switching FET based DC-DC design that minimizes primary side ripple current and noise. The dual drive, coupled with a custom transformer designed for low inter-winding capacitance, further minimizes switching noise injection from primary to secondary side, and into the board's low voltage ground (LV_GND).

A two switch converter drives the transformer differentially and as a result several advantages are realized. During ON time, the primary transformer current is shared by the FETs M1 and M2 so that the parasitic inter-winding capacitance is driven differentially. Dual drive helps to balance charge injection into the secondary. During OFF time, D1 and D2 catch the voltage reversal on the transformer primary terminal and several important actions occur during this interval. The transformer core is reset, to balance the V-S product across the transformer windings. More importantly, the energy stored in the leakage inductance is recycled back into the primary

bulk capacitor C1. This greatly reduces the ringing associated with absorbing the leakage energy and also increases efficiency. A single switch solution requires a snubbing circuit to absorb the leakage energy (which bleeds into the supply line) and some additional method is needed to reset the transformer core (e.g. a separate reset winding). Additionally, since two switches share the primary load, lower breakdown transistors can be used and reliability is improved.

The figure above shows the converter in the Kinetic PD operating in the forward configuration and two primary (high and low side) switches. The AS1113 and AS1114 can also be used in a flyback topology. As described above, using a dual FET transformer drive reduces noise injected into the line and the load, increases efficiency and reliability. Drivers for switching FET's have been carefully balanced with matching slew rates to further minimize the effect of switching noise.

In general, the power transformers are custom designed, depending on the desired output voltage and converter topology (Forward, Flyback, Isolated Buck, etc.) To minimize the cost and circuit footprint, the transformer use the smallest core sizes, based on Wattage and efficiency requirement of the applications. Care is also taken in selecting the internal insulation, to significantly reduce the inter-winding capacitance, and hence noise injection from primary to secondary ground.

For superior EMI performance, Forward topology with dual switching FETs is recommended for both the AS1113 and AS1114. The Forward topology minimizes peak currents and injected noise. The results below indicate that the AS1113 meets Class B compliance with 9db of margin.

SUMMARY

Managing noise in PoE systems is a challenging task, since there is direct path from the switching DC-DC converters to the UTP. Meeting EMC compliance requires careful system design and use of additional chokes on the PoE power connection, to achieve desirable level of performance. The Kinetic proprietary architecture comprises several functional blocks, which when combined in the PD silicon can reduce EMI significantly compared to traditional solutions.

There are many other factors that can impact EMI performance in any system. A primary factor is board layout. Using AS1113 and AS1114 still require system designer to follow good EMC design practices, especially related to signal routing and power-supply decoupling/filtering.

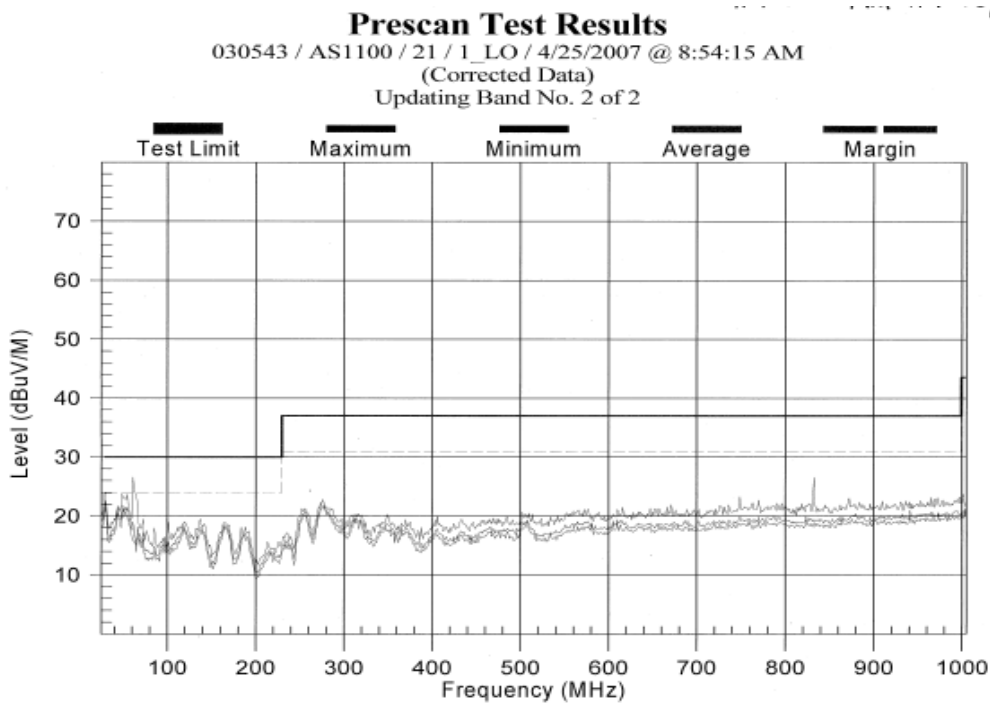

Figure 2, FCC Class B Test Results for Kinetic AS1113 PD Controller

NOTES



CONTACT INFORMATION

Kinetic Technologies
6399 San Ignacio Ave, Suite 250,
San Jose, CA 95119 USA

Tel: (408) 746-9000
Fax: (408) 351-0338
Email inquiries: info@kinet-ic.com
Website: <http://www.kinet-ic.com>

IMPORTANT NOTICES

LEGAL NOTICE

Copyright © 2006 Kinetic Technologies. All rights reserved.

Other names, brands, and trademarks are the property of others.

Kinetic Technologies assumes no responsibility or liability for information contained in this document. Kinetic reserves the right to make corrections, modifications, enhancements, improvements, and other changes to its products and services at any time and to discontinue any product or services without notice. The information contained herein is believed to be accurate and reliable at the time of printing.

LIFE AND SAFETY POLICY

Kinetic' products are not authorized for use as critical components in life support systems for surgical implant into the body, or other applications intended to support or sustain life or any other applications whereby a failure of the Kinetic product could create a situation where personal injury, death or damage to persons, systems, data or business may occur.