

Surge Protected, Single Input, Dual Output Load Switch with OVP

Features

- Single Input, Dual Output Low On- Resistance Switch
 - ▶ VBUS to OUT: typ. 23mΩ
 - ▶ VBUS to SYS: typ. 30mΩ (Reverse Blocking)
- Wide Input Voltage Range: 2.7V – 28V
 - ▶ VBUS Abs Max: 28V
- Surge and ESD Protected Input
 - ▶ Surge Protection
 - IEC61000-4-5: > ±100V
 - ▶ ESD Protection
 - IEC61000-4-2 (Level 4) VBUS
 - Contact: ±8kV
 - Air Gap: ±15kV
 - HBM: 2kV All Pins
- Integrated Over-voltage Protection (OVP)
 - ▶ VBUS to OUT: 5.95V
 - ▶ VBUS to SYS: 5.25V
- Maximum Continuous Current
 - ▶ VBUS to OUT: 3.5A
 - ▶ VBUS to SYS: 6A
- Dual Enable Control with Independent Shutdown Control
 - ▶ Active LOW VBUS to OUT
 - ▶ Active HIGH VBUS to SYS
 - ▶ Active HIGH Shutdown
- VBUS detection LDO
- VBUS to SYS FLAG
- Over Temperature Protection
- Pb-free 28-Bump, WLCSP 2.96mm x 1.67mm
- -40°C to 85°C Operating Temperature Range

Brief Description

The KTS1678C features two low resistance power switches configured as single input, dual output, change-over switch. The input to both switches is protected against VBUS surge voltages of up to ±100V, and is also protected against over-voltage, with preset trip points on both the VBUS to OUT and VBUS to SYS paths, providing protection to downstream components from abnormal input conditions.

The main switch (VBUS to OUT) features a unidirectional active-LOW enabled 3.5A rated MOSFET, with an OVP trip point of 5.95V. The secondary switch (VBUS to SYS) is an active-HIGH enabled, reverse-blocking 6.0A rated MOSFET, with an OVP trip point of 5.25V. The input to both switches is rated up to a maximum of 28V.

When VBUS is greater than 2.7V, the POK LDO provides an “always ON” power source, regardless of the OVLO, EN1 and EN2 state, to power downstream components permitting operation without an installed battery.

The KTS1678C also features an active-HIGH SHUTDOWN pin to conserve power, plus over-temperature thermal protection.

The KTS1678C is packaged in advanced, fully “green” compliant, 2.96mm x 1.67mm, Wafer-Level Chip-Scale Package (WLCSP).

Applications

- Smartphones and Tablets
- Mobile Internet Devices
- Wearables
- Portable Devices

Typical Application

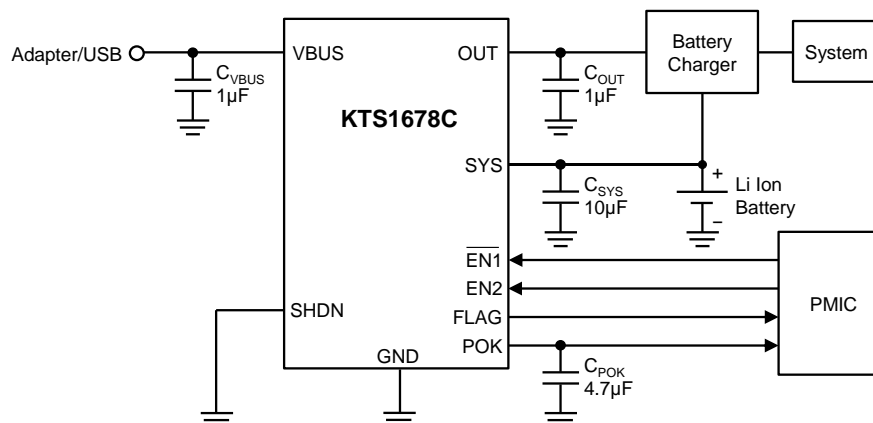

Pin Descriptions

Pin #	Name	Function
A1	FLAG	Active HIGH CMOS Power good for VBUS to SYS path.
A2	SHDN	Active HIGH input with internal 1MΩ pull-down resistor, for device shutdown.
A3	POK	Regulated output whenever VBUS is present
A4	EN1	Active LOW enable with internal 1MΩ pull-down resistor, for VBUS to OUT path only
B1, B2, C1	OUT	Power switch output to load
B3, C2, C3, C4, D2, D3, D4, E2, E3, E4, F2, F3, F4	VBUS	Input to the power switches and device supply
B4	EN2	Active HIGH enable with internal 1MΩ pull-down resistor, for VBUS to SYS path only
D1, E1, F1	SYS	Power switch output to battery
G1, G2, G3, G4	GND	Ground

WLCSP47-28

TOP VIEW

TOP VIEW

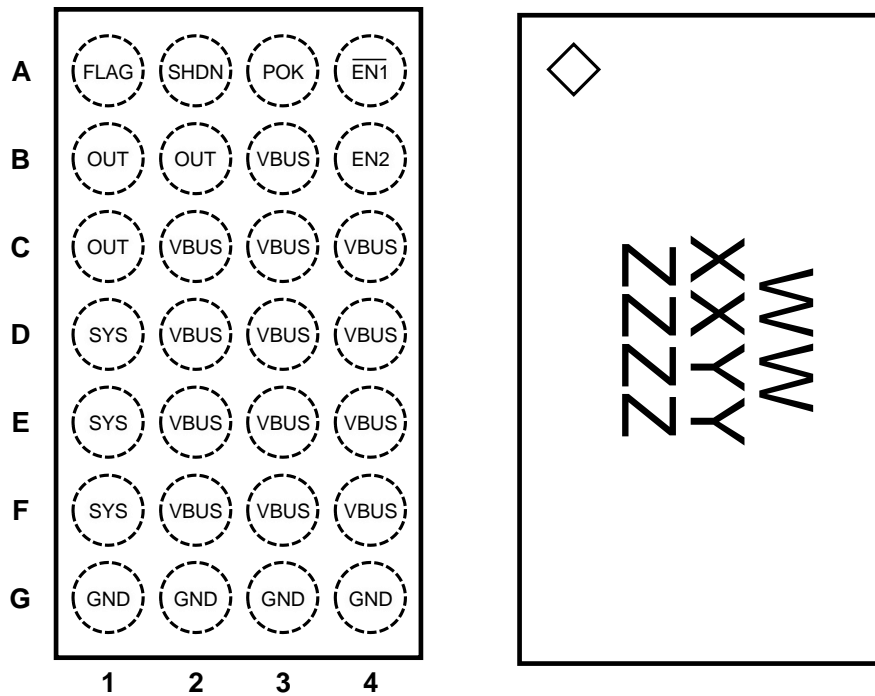

28-Bump 2.96mm x 1.67mm x 0.620mm
WLCSP Package

Top Mark
WW = Device ID Code,
XX = Date Code, YY = Assembly Code
ZZZZ = Serial Number

Absolute Maximum Ratings¹

(T_A = 25°C unless otherwise noted)

Symbol	Description	Value	Units
VBUS ²	VBUS to GND & VBUS to VOUT = GND or Float	-2 ³ to 28	V
OUT	OUT to GND	-0.3 to VBUS+0.3	V
SYS	SYS to GND	-0.3 to 6	V
SHDN, EN1, EN2, POK, FLAG	Shutdown, Enable, POK and Flag pins	-0.3 to 6	V
VBUS-OUT Current	VBUS to OUT Continuous Current	3.5	A
	VBUS to OUT Peak Current (5ms)	7.0	A
VBUS-SYS Current	VBUS to SYS Continuous Current	6.0	A
	VBUS to SYS Peak Current (5ms)	12.0	A
T _J	Operating Temperature Range	-40 to 150	°C
T _S	Storage Temperature Range	-65 to 150	°C
T _{LEAD}	Maximum Soldering Temperature (at leads, 10 sec)	260	°C

Thermal Capabilities⁴

Symbol	Description	Value	Units
Θ _{JA}	Thermal Resistance – Junction to Ambient	55	°C/W
P _D	Maximum Power Dissipation at 25°C	2.27	W
ΔP _D /ΔT	Derating Factor Above T _A = 25°C	-41.3	mW/°C

Ordering Information

Part Number	Marking	Operating Temperature	Package
KTS1678CEUQ-TR	NGXXYYZZZ ⁵	-40°C to +85°C	WLCSP28

- Stresses above those listed in Absolute Maximum Ratings may cause permanent damage to the device. Functional operation at conditions other than the operating conditions specified is not implied. Only one Absolute Maximum rating should be applied at any one time.
- Survives burst pulse up to 100V with 2Ω series impedance.
- Pulsed, 50ms maximum non-repetitive.
- Junction to Ambient thermal resistance is highly dependent on PCB layout. Values are based on thermal properties of the device when soldered to an EV board.
- XX = Date Code, YY = Assembly Code, ZZZZ = Serial Number.

Electrical Characteristics⁶

Unless otherwise noted, the *Min* and *Max* specs are applied over the full operation temperature range of -40°C to +85°C, $V_{BUS} = 2.7V$ to $5.8V$. Typical values are specified at room temperature (25°C) with $V_{BUS} = 5V$, $I_{BUS} \leq 2A$, SHDN = $\overline{EN1} = EN2 = LOW$, POK = OPEN, $C_{IN} = 0.1\mu F$ and $T_A = 25^\circ C$.

Symbol	Description	Conditions	Min	Typ	Max	Units	
Input							
I_Q	Input Quiescent Current	$V_{BUS} = 5V, \overline{EN1} = EN2 = LOW$		139	215	μA	
I_{LK}	Input Leakage Current	$V_{BUS} = 5V, SHDN = HIGH$			0.7	μA	
I_{OVLO_Q}	Input Supply Current in Over-voltage mode	$V_{BUS} = 6.5V, OUT = 0V, \overline{EN1} = EN2 = LOW$		165	290	μA	
		$V_{BUS} = 5.5V, SYS = 0V, \overline{EN1} = EN2 = HIGH$		146	210	μA	
V_{IN_CLAMP}	Input Clamp Voltage	$I_{IN} = 10mA, T_A = 25^\circ C$	31	32.5	34	V	
V_{BUS_UVLO}	Under Voltage Lockout	V_{BUS} Rising	2.35	2.50	2.65	V	
		V_{BUS} Falling	2.15	2.35	2.50	V	
OVP VBUS to OUT							
R_{ON_OUT}	ON-Resistance VBUS to OUT	$V_{BUS} = 5V, I_{OUT} = 1A, T_A = 25^\circ C$		23	39	m Ω	
V_{OUT_OVLO}	Over-Voltage Trip Level	V_{BUS} Rising, $T_A = 25^\circ C$	5.90	5.95	5.99	V	
		V_{BUS} Falling, $T_A = 25^\circ C$	5.70			V	
OVP VBUS to SYS							
R_{ON_SYS}	ON-Resistance VBUS to SYS	$V_{BUS} = 3V, I_{OUT} = 1A, T_A = 25^\circ C$		30	40	m Ω	
V_{SYS_OVLO}	Over-Voltage Trip Level	V_{BUS} Rising	5.00	5.25	5.50	V	
		V_{BUS} Falling	4.80			V	
I_{SYS_RB}	SYS Reverse Current	$V_{BUS} = 0V, V_{SYS} = 4.4V, T_A = 25^\circ C$			1	μA	
I_{VBUS_RB}	SYS-to-VBUS Reverse Current	$V_{SYS} = 4.4V, V_{BUS} = 0V, T_A = 25^\circ C$, measured at VBUS, no ambient light		0.05	2	nA	
POK							
POK	POK Output Voltage	$V_{BUS} = 5V, I_{POK} = 0mA$	$T_A = 25^\circ C$	3.6	4.0	4.4	V
		$V_{BUS} = 6.5V, I_{POK} = 0mA$		3.6	4.0	4.4	V
		$V_{BUS} = 5V, I_{POK} = 100mA$		3.6	3.96	4.4	V
		$V_{BUS} = 6.5V, I_{POK} = 100mA$		3.4	3.99	4.4	V
I_{LK_POK}	POK-to-GND Leakage Current	$V_{POK} = 5V, V_{BUS} = 0V, T_A = 25^\circ C$		0.01	1	μA	
I_{POK_VBUS}	POK-to-VBUS Leakage Current	$V_{POK} = 5V, V_{BUS} = 0V, T_A = 25^\circ C$, measured at VBUS, no ambient light		0.05	2	nA	
DIGITAL SIGNALS (FLAG, $\overline{EN1}$, EN2)							
V_{FLAG_OH}	FLAG Output HIGH Voltage	$V_{BUS} = 5V, EN2 = HIGH$	1.6	1.81	2.0	V	
V_{FLAG_OL}	FLAG Output LOW Voltage	$V_{BUS} = 5V, EN2 = LOW$			0.5	V	
V_{IH}	Logic $\overline{EN1}$, EN2, SHDN, HIGH Voltage	$V_{BUS} = 2.7V$ to $5.8V$	1.2			V	
V_{IL}	Logic $\overline{EN1}$, EN2, SHDN, LOW Voltage				0.35	V	
I_{EN_SHDN}	$\overline{EN1}$ Leakage Current	$V_{BUS} = 5V, OUT, SYS = Float$		4.3	7	μA	
	EN2, SHDN Leakage Current			5.1			
R_{PD}	$\overline{EN1}$, EN2, SHDN Internal Pull-down Resistor			1		M Ω	

6. KTS1678C is guaranteed to meet performance specifications over the -40°C to +85°C operating temperature range by design, characterization and correlation with statistical process controls.

Electrical Characteristics (continued)⁷

Unless otherwise noted, the *Min* and *Max* specs are applied over the full operation temperature range of -40°C to +85°C, $V_{BUS} = 2.7V$ to $5.8V$. Typical values are specified at room temperature (25°C) with $V_{BUS} = 5V$, $I_{VBUS} \leq 2A$, $SHDN = \overline{EN1} = \overline{EN2} = LOW$, $POK = OPEN$, $C_{IN} = 0.1\mu F$ and $T_A = 25^\circ C$.

Symbol	Description	Conditions	Min	Typ	Max	Units
TIMING CHARACTERISTICS (Figures 1-6)						
OUT						
t_{OUT_SS}	VOUT Soft-Start Time	Time from $V_{BUS} = V_{BUS_UVLO}$ to 10% of POK		30		ms
t_{DEB_OUT}	OUT Debounce Time	Time from $V_{BUS_UVLO} < V_{BUS} < V_{OUT_OVLO}$ to 10% of V_{OUT}		16		ms
t_{ON_OUT}	OUT Switch Turn-on Time	V_{OUT} from 10% of V_{BUS} to 90% of V_{BUS} , $R_L = 100\Omega$, $C_L = 10\mu F$		2		ms
t_{OFF_OUT}	OUT Switch Turn-off Time ⁸	$V_{BUS} > V_{OUT_OVLO}$ to V_{OUT} Stop rising, $R_L = 100\Omega$, No C_L		250		ns
SYS						
t_{SYS_SS}	VSYS Soft-Start Time	Time from $V_{BUS} = V_{BUS_UVLO}$ to 10% of FLAG		30		ms
t_{DEB_SYS}	SYS Debounce Time	Time from $V_{BUS_UVLO} < V_{BUS} < V_{OUT_OVLO}$ to 10% of V_{SYS}		16		ms
t_{ON_SYS}	SYS Switch Turn-on Time	V_{SYS} from 10% of V_{BUS} to 90% of V_{BUS} , $R_L = 100\Omega$, $C_L = 10\mu F$		2.5		ms
t_{OFF_SYS}	SYS Switch Turn-off Time ⁸	$V_{BUS} > V_{SYS_OVLO}$ to V_{SYS} Stop rising, $R_L = 100\Omega$, No C_L		400		ns
THERMAL SHUTDOWN⁸						
t_{L_TH}	IC Junction Thermal Shutdown			150		°C
	IC Junction Thermal Shutdown Hysteresis			20		°C
ESD PROTECTION⁸						
V_{ESD}	Human Body Model (HBM)	All pins		±2		kV
	IEC61000-4-2 Contact Discharge	VBUS Pin		±8		kV
	IEC61000-4-2 Air Discharge	VBUS Pin		±15		kV

7. KTS1678C is guaranteed to meet performance specifications over the -40°C to +85°C operating temperature range by design, characterization and correlation with statistical process controls.

8. Guaranteed by characterization and design

Timing Diagrams

VBUS to OUT

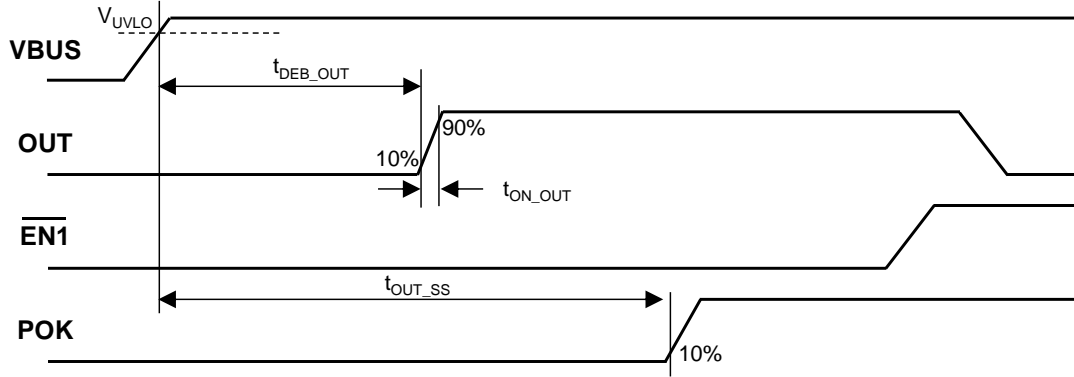

Figure 1. VBUS to OUT Timing Power Up/Down and Normal Operation

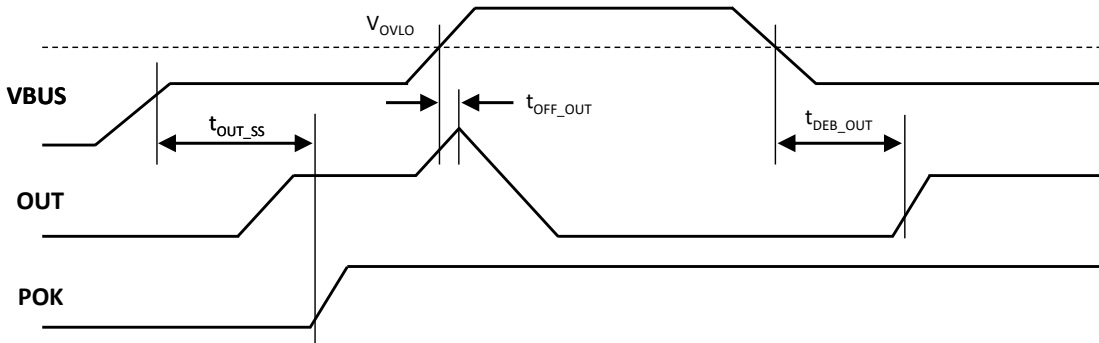

Figure 2. VBUS to OUT Timing OVLO Operation ($\overline{EN1} = \text{LOW}$)

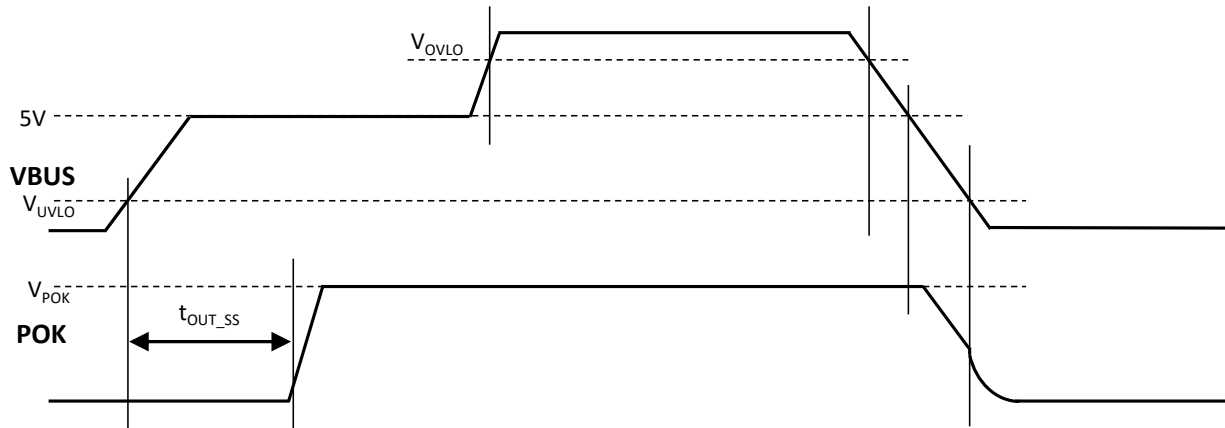

Figure 3. POK Always ON Timing ($\overline{EN1} = \text{X}$, $\text{EN2} = \text{X}$, $\text{SHDN} = \text{LOW}$)

VBUS to SYS

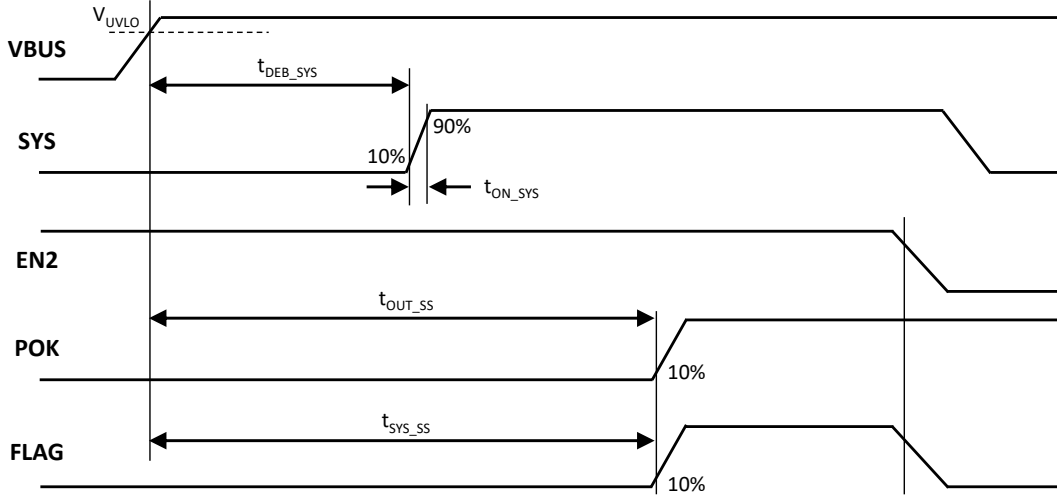

Figure 4. VBUS to SYS Timing Power Up/Down and Normal Operation

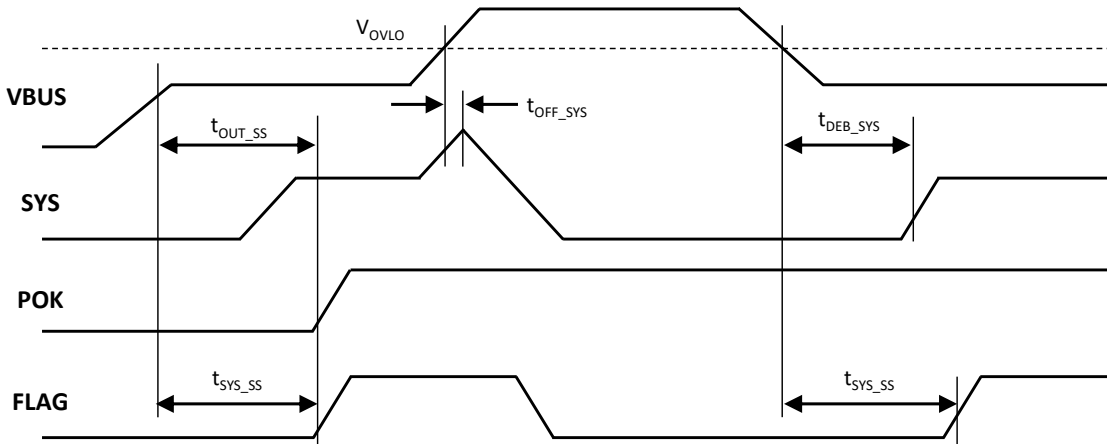

Figure 5. VBUS to SYS Timing OVLO Operation (EN2 = HIGH)

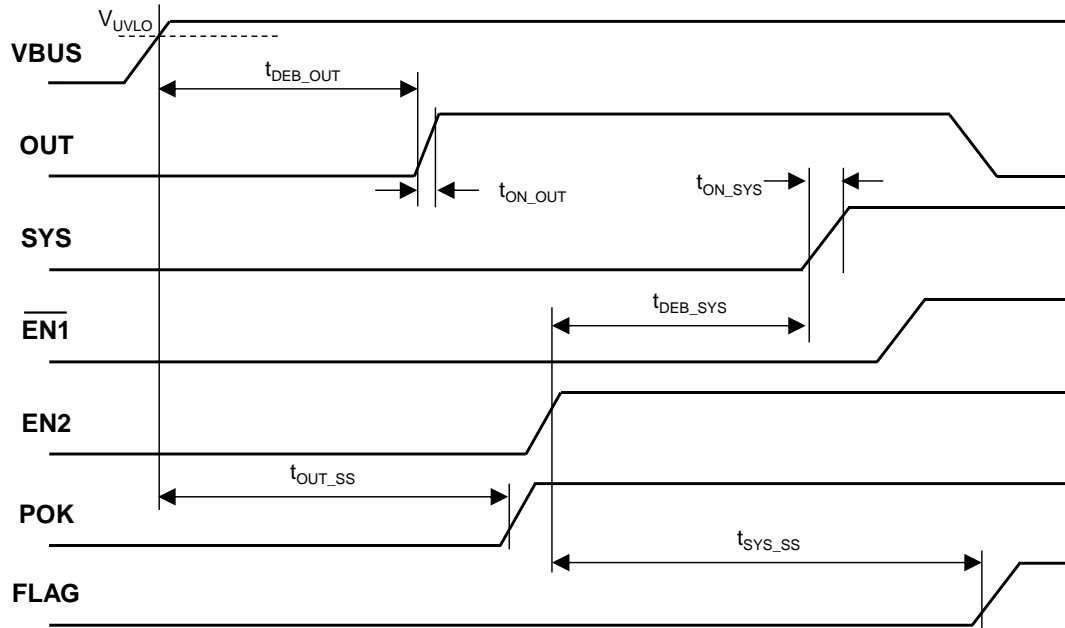
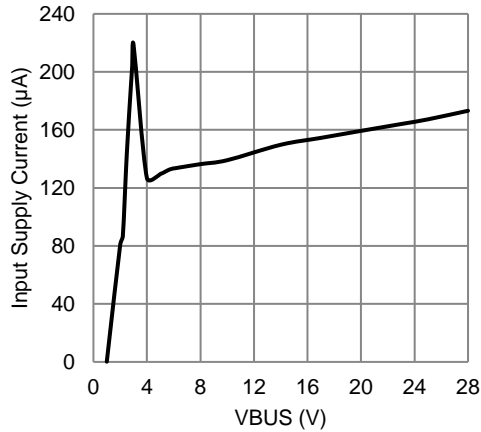

Figure 6. ON to OFF Timing Normal Operation (SHDN = LOW)

Typical Characteristics

$V_{BUS} = 5V$, $C_{VBUS} = 0.1\mu F$, $C_{OUT} = 1\mu F$, $C_{SYS} = 10\mu F$, $C_{POK} = 4.7\mu F$, $T_A = 25^\circ C$ unless otherwise specified.

Input Supply Current vs. VBUS Voltage (No Load)



Input Supply Current vs. Temperature

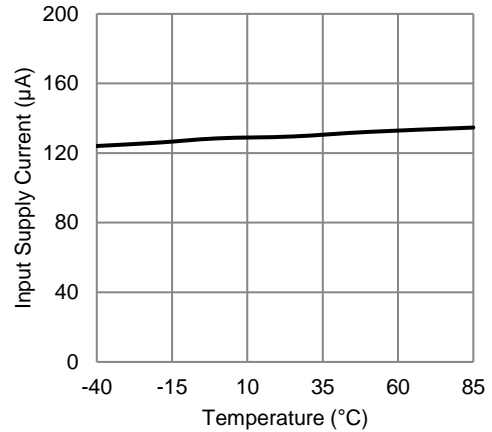

Normalized R_{OUT_ON} vs Output Current

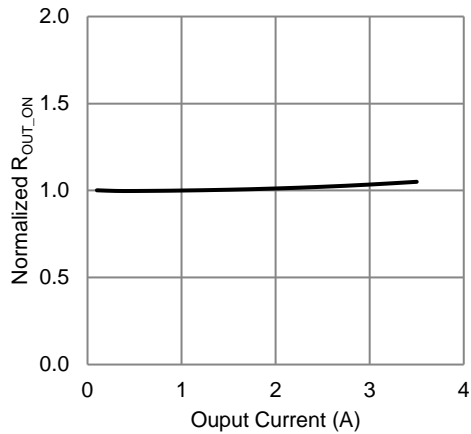

Normalized R_{OUT_ON} vs. Temperature

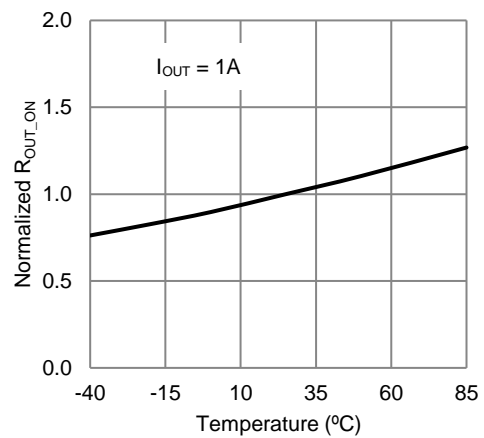

Normalized R_{SYS_ON} vs Output Current

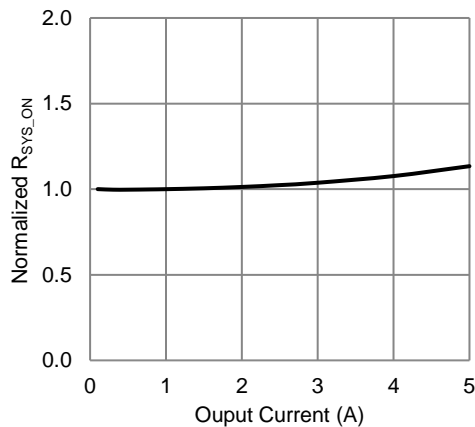

Normalized R_{SYS_ON} vs. Temperature

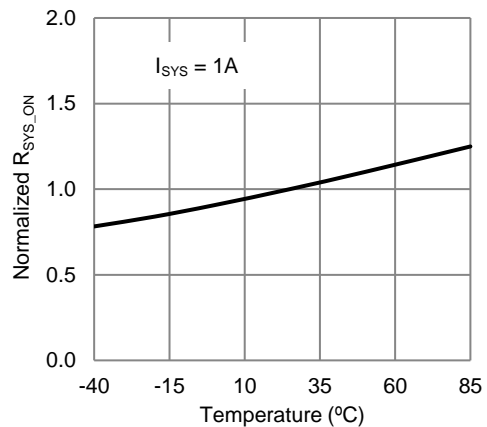

Typical Characteristics (continued)

$V_{BUS} = 5V$, $C_{VBUS} = 0.1\mu F$, $C_{OUT} = 1\mu F$, $C_{SYS} = 10\mu F$, $C_{POK} = 4.7\mu F$, $T_A = 25^\circ C$ unless otherwise specified.

Normalized VOUT OVLO vs Temperature

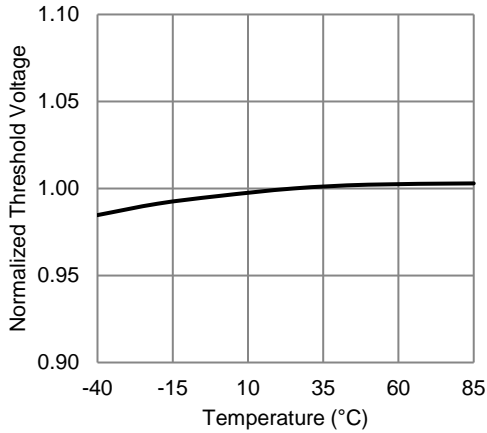

Normalized VSYS OVLO Threshold vs Temperature

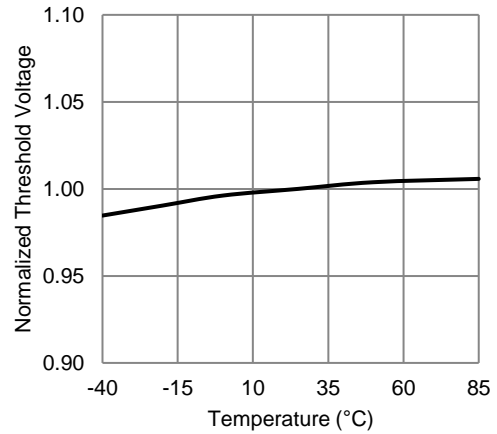

Normalized Debounce Time vs. VBUS

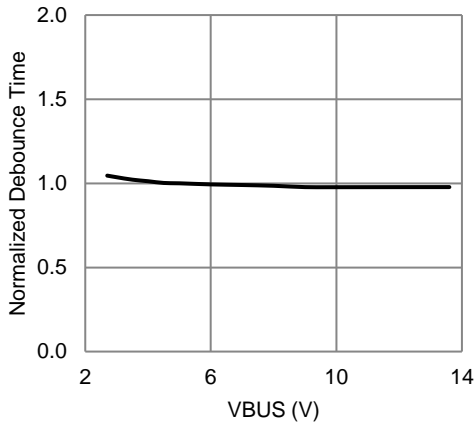

Normalized Debounce Time vs. Temperature

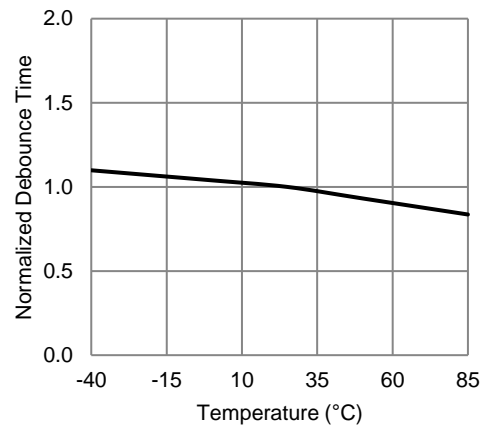

VPOK vs. VBUS

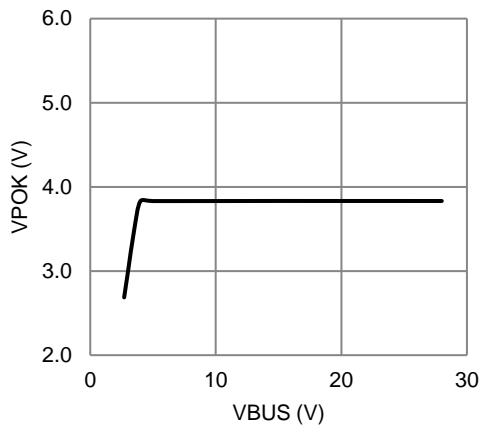

VPOK vs Temperature

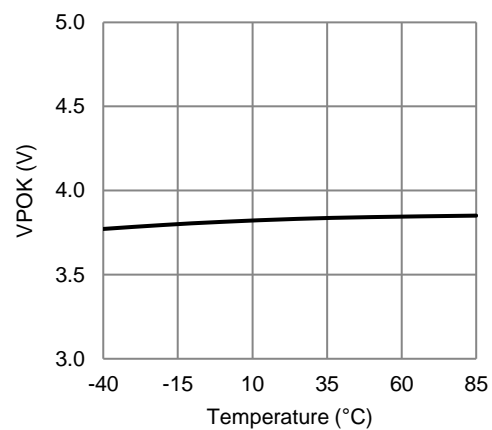

Typical Characteristics (continued)

$V_{BUS} = 5V$, $C_{VBUS} = 0.1\mu F$, $C_{OUT} = 1\mu F$, $C_{SYS} = 10\mu F$, $C_{POK} = 4.7\mu F$, $T_A = 25^\circ C$ unless otherwise specified.

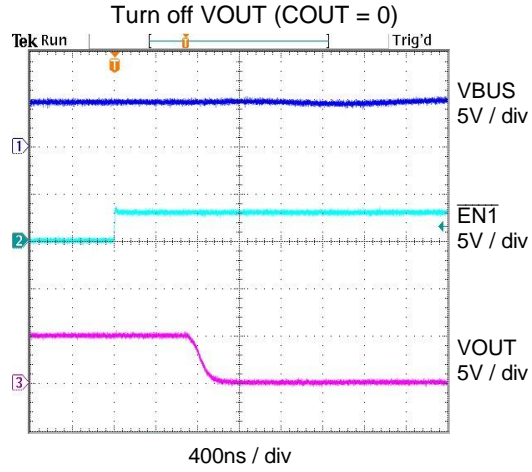
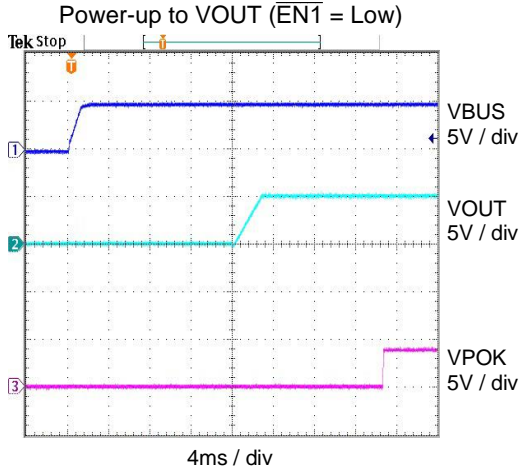

Power-up to VSYS ($V_{BUS} = 4V$, $EN2 = \text{High}$)

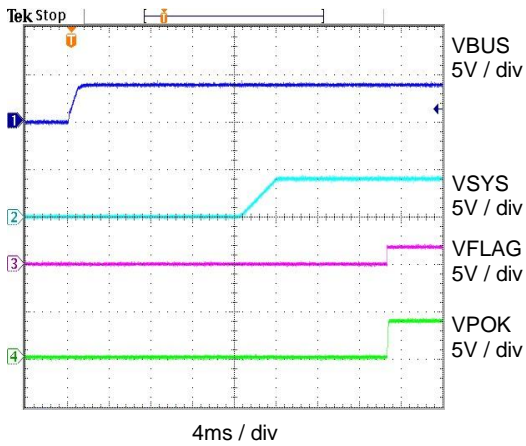

Surge Transient (100V)

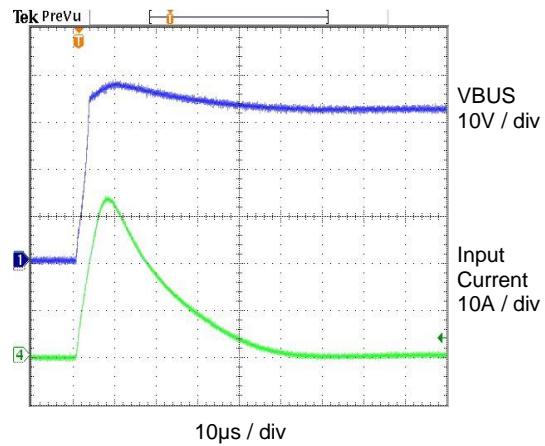

Functional Block Diagram

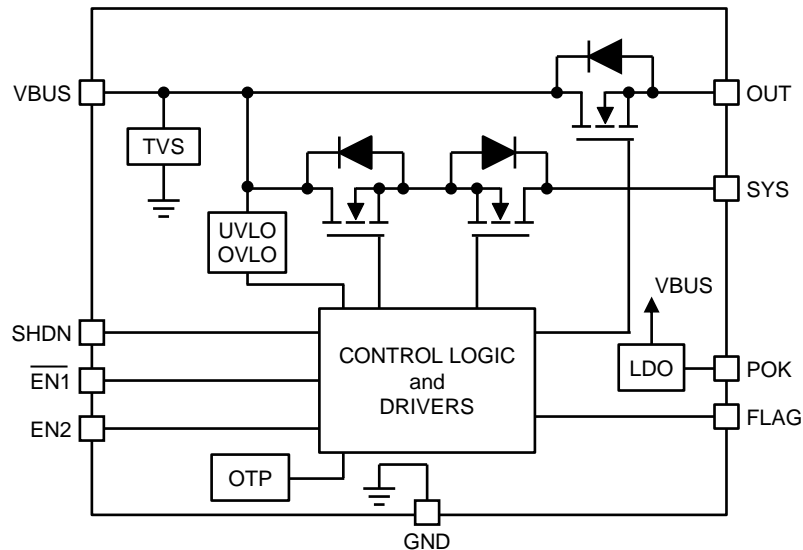

Functional Description

The KTS1678C features two low resistance power switches configured as single input, dual output, change-over switch. The input to both switches is protected against VBUS surge voltages of up to $\pm 100V$, and is also protected against over-voltage, with preset trip points on both the VBUS to OUT and VBUS to SYS paths, providing protection to downstream components from abnormal input conditions.

The main switch (VBUS to OUT) features a unidirectional active-LOW enabled 3.5A rated MOSFET, with an OVP trip point of 5.95V. The secondary switch (VBUS to SYS) is an active-HIGH enabled, reverse-blocking 6.0A rated MOSFET, with an OVP trip point of $5.25V \pm 250mV$. The input to both switches is rated up to a maximum of 28V and includes a 15ms debounce time, ensuring that the input VBUS input is stable.

When VBUS is greater than the UVLO of typically 2.7V, the POK LDO provides an “always ON” power source, regulated to typically 4V, regardless of the status of OVLO, $\overline{EN1}$ and EN2, to power downstream components permitting operation without an installed battery. The POK LDO is capable of supplying up to 100mA of output current.

The KTS1678C also features an active-HIGH shutdown pin (SHDN) to conserve power, plus over-temperature thermal protection circuitry with hysteresis.

An active HIGH, CMOS FLAG is asserted whenever the SYS switch is active and is in a normal operating mode. The FLAG is deasserted when the SYS switch is OFF due to either EN2 = LOW, VBUS is in UVLO or OVLO, thermal shutdown or SHDN = HIGH.

The truth table for KTS1678C is shown in Table 1 below.

Table 1. KTS1678C Truth Table

SHDN	$\overline{EN1}$ (OUT)	EN2 (SYS)	OUT SW	SYS SW	FLAG	POK
0	0	0	ON	OFF	LOW	ON
0	1	0	OFF	OFF	LOW	ON
0	0	1	ON	ON	HIGH	ON
0	1	1	OFF	ON	HIGH	ON
1	x	x	OFF	OFF	LOW	OFF

X = Don't Care

Applications Information

Input Capacitor

A 0.1 μ F capacitor is typically recommended for C_{VBUS} . C_{VBUS} should be located as close to the device VBUS pin as practically possible. 50V rated capacitors are generally good for most OVP applications to support any surge transient voltage.

Output Capacitors

The soft-start function provides a slow turn-on that allows the KTS1678C to charge large C_{SYS}/C_{OUT} output capacitors with minimum in-rush current. It is recommended to bypass SYS/OUT/POK outputs with a 1 μ F minimum ceramic capacitor.

Recommended PCB Layout

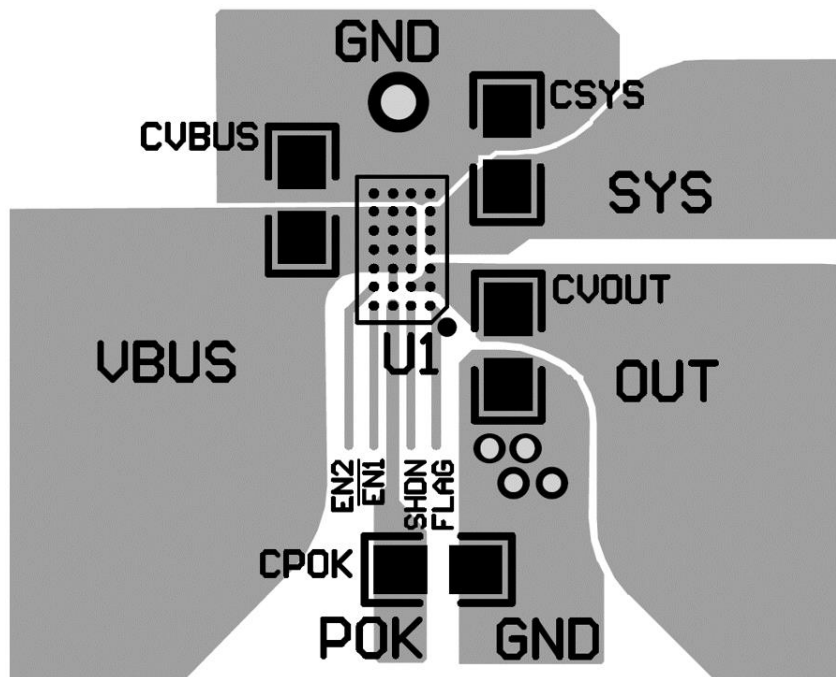
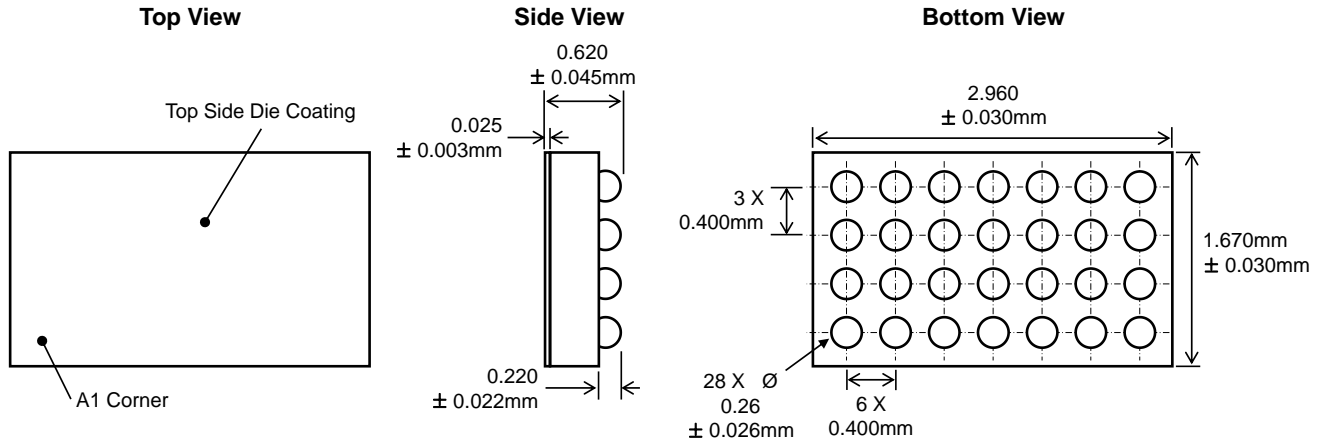

Figure 7. Recommended PCB Layout

Packaging Information

WLCSP47-28



Recommended Footprint

(NSMD Pad Type)

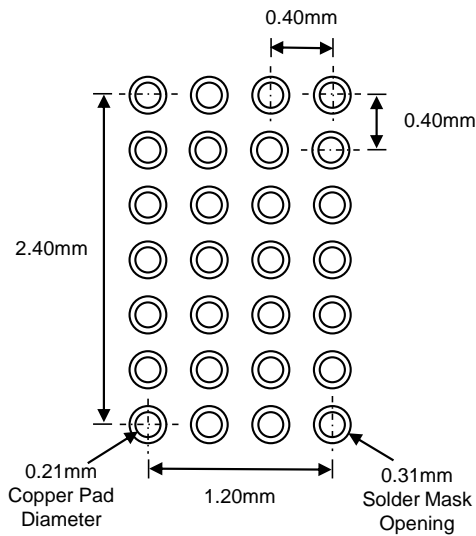

* Dimensions are in millimeters.

Kinetic Technologies cannot assume responsibility for use of any circuitry other than circuitry entirely embodied in a Kinetic Technologies product. No intellectual property or circuit patent licenses are implied. Kinetic Technologies reserves the right to change the circuitry and specifications without notice at any time.